

Introduction to Sources: Radiative Processes and Population Inversion in Atoms, Molecules, and Semiconductors

Atoms and Molecules

Energy Levels

Every atom or molecule has a collection of discrete energy levels that may be irregularly spaced. Figure 1 shows six levels in a hypothetical collection. Each of the energy levels may be comprised of multiple sublevels of the same energy, in which case we say that the energy level is degenerate. For the time being we will ignore degeneracy. As pictured in Figure 1, the atom or molecule is in level 1.

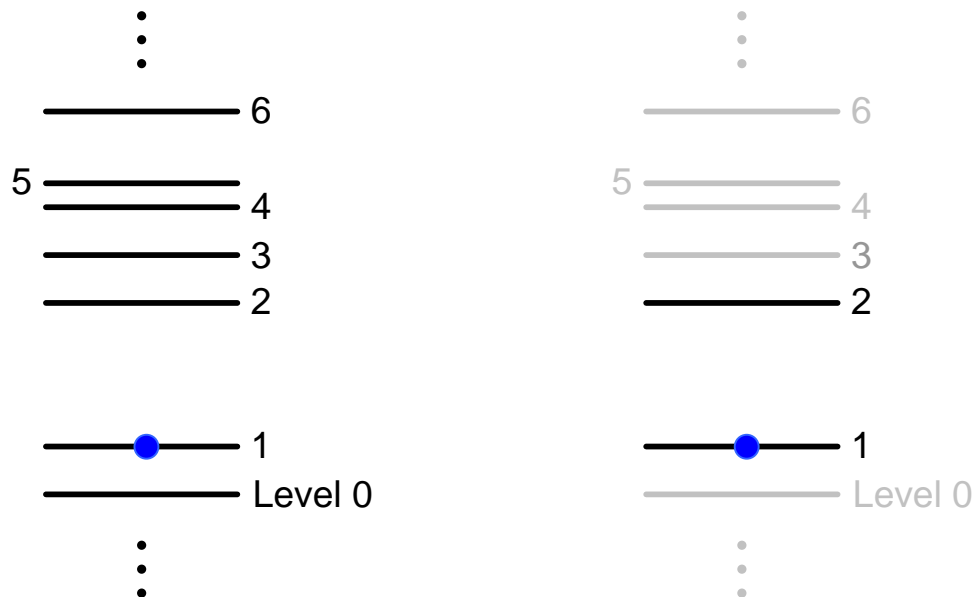

Figure 1. Energy levels for an atom or molecule. Frequently we will discuss the interaction of light with just two of the levels.

Monochromatic light generated by a laser may interact strongly with only two levels, say levels 1 and 2, if the photon energy equals the

difference in the energy of the two levels (i.e. $h\nu = E_2 - E_1$). In this case we say that the light interacts resonantly with levels 1 and 2, and we often focus our attention on these levels and, at least temporarily, ignore the rest. From here on we will refer to an atom or molecule as a particle.

We almost always deal with a collection of particles, each of which may be in a different energy level as pictured in Figure 2. Because the number of particles may be very large, it is common to use a visual shorthand and represent the collection with just two levels as in Figure 3.

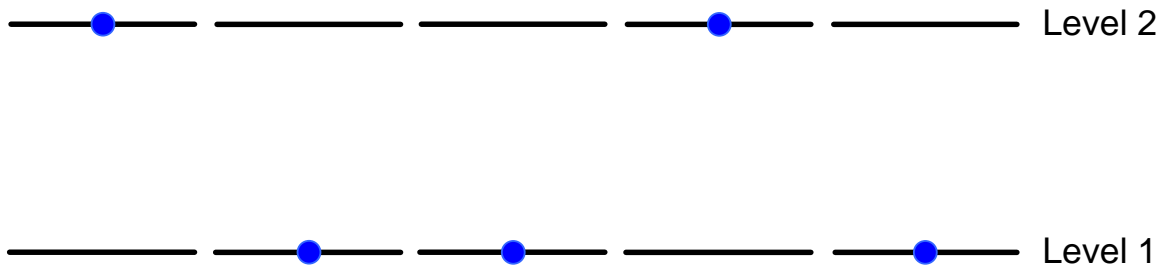

Figure 2. A collection of five particles with energies distributed between the energy levels.

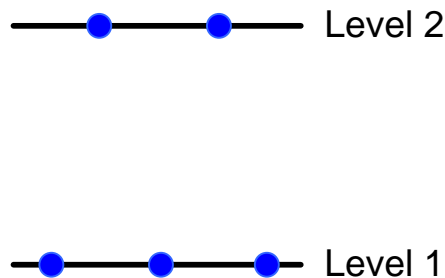

Figure 3. A shorthand version of the diagram in Figure 2.

In order to describe the operation of a laser and other optoelectronic devices, we enumerate three radiative processes involving the interaction

of a photon with two energy levels in a particle: absorption, stimulated emission, and spontaneous emission.

Absorption

A photon resonant with two energy levels can cause a transition to higher energy as pictured in Figure 4. The process is called photon absorption, and the end result is that an additional particle occupies energy level 2 and there is one less photon in the system. In the language of quantum electrodynamics we say that the photon has been destroyed.

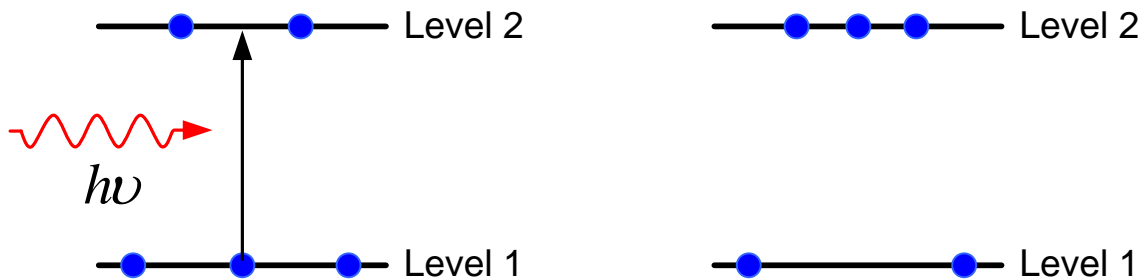

Figure 4. A photon is absorbed as a particle is excited from energy level 1 to energy level 2.

The strength of the interaction between the photon and the levels is proportional to the dipole moment of the two levels:

$$\mu \equiv \int_{\text{All Space}} dr^3 q u_2(\vec{r}) \vec{r} u_1(\vec{r}),$$

where u_1 and u_2 are the wavefunctions for electrons in levels 1 and 2 respectively. In some cases, it we may find that $\mu = 0$. Then we say that the transition is not allowed. This is an example of a “selection rule” for an

optical transition. The strength of all three radiative processes considered in this section are proportional to the dipole moment μ .

Stimulated Emission

A photon resonant with two energy levels can also stimulate a transition to lower energy as pictured in Figure 5. The process, called stimulated emission, creates an additional photon.



Figure 5. A Photon stimulates a particle to a lower energy level, creating a second photon.

Spontaneous Emission

Unlike absorption and emission, the third radiative process, spontaneous emission, is not initiated by a photon. It is possible for a particle to undergo a spontaneous transition to lower energy while emitting a photon. Quantum electrodynamics describes this process, pictured in Figure 6, as a transition initiated by fluctuations of the electromagnetic vacuum.

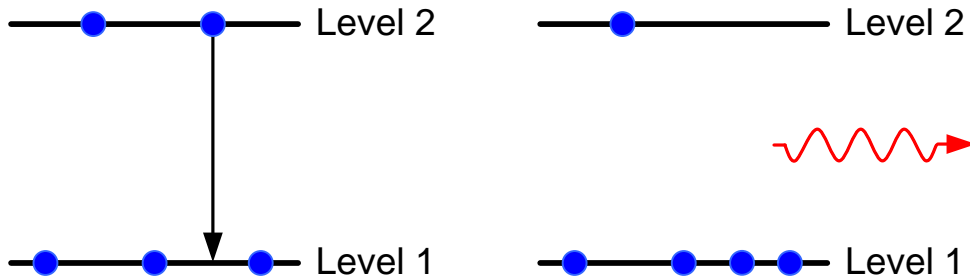

Figure 6. A particle spontaneously emits a photon.

Population Inversion

When resonant photons are incident on a collection of particles with a distribution of energies in both level 1 and level 2, we expect all three radiative processes (absorption, stimulated emission, spontaneous emission) to take place. If the flux of incident photons is large, the stimulated transitions (i.e. absorption and stimulated emission) will occur most rapidly and we can neglect spontaneous emission.

If, in addition, more particles are initially in level 2 than in level 1 (Figure 7), then stimulated emission dominates absorption and a resonant light beam will gain intensity as it traverses the volume occupied by the particles. This is the opposite of what is typically observed when a light beam traverses a medium – absorption. Unless they have been suitably prepared, most media have larger populations in lower energy levels. It is for this reason that we call the condition that produces optical gain a population inversion. To be more quantitative, we say we have a population inversion provided

$$N_2 - N_1 > 0,$$

where N_2 is the number of particles per unit volume in level 2 and N_1 is the number of particles per unit volume in level 1. If the energy levels are degenerate (i.e. contain sublevels), then the condition for population conversion and optical gain is

$$g_1 N_2 - g_2 N_1 > 0,$$

where g_1 is the number of sublevels in level 1 and g_2 is the number of sublevels in level 2.

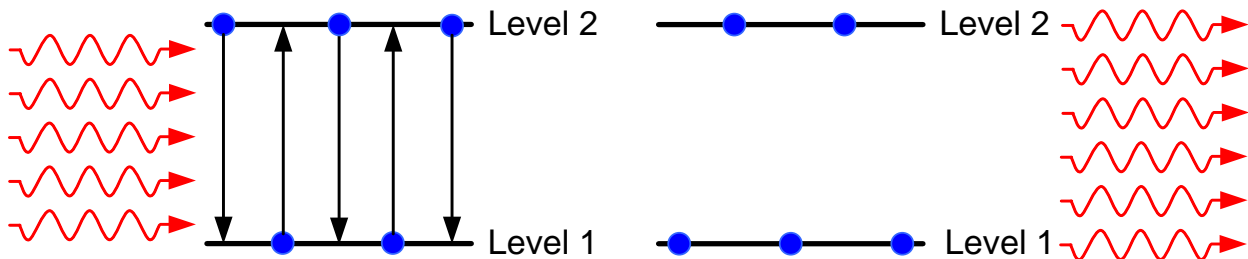

Figure 7. An “inverted” population amplifies light.

Semiconductors

Energy Levels

Semiconductors are also characterized by a collection of energy levels. However, the energy levels of interest are grouped into bands of very closely spaced levels (Figure 8). Bands are approximately one eV in width and contain on the order of 10^8 levels. Each level is doubly degenerate, containing a sublevel that can be filled by a “spin up” electron and a sublevel that can be occupied by a “spin down” electron. Within a band, levels, or states as they are often called, are labeled by a wavenumber k .

The quantity $\hbar k$ represents the linear momentum of the electron or, more precisely, its crystal momentum.

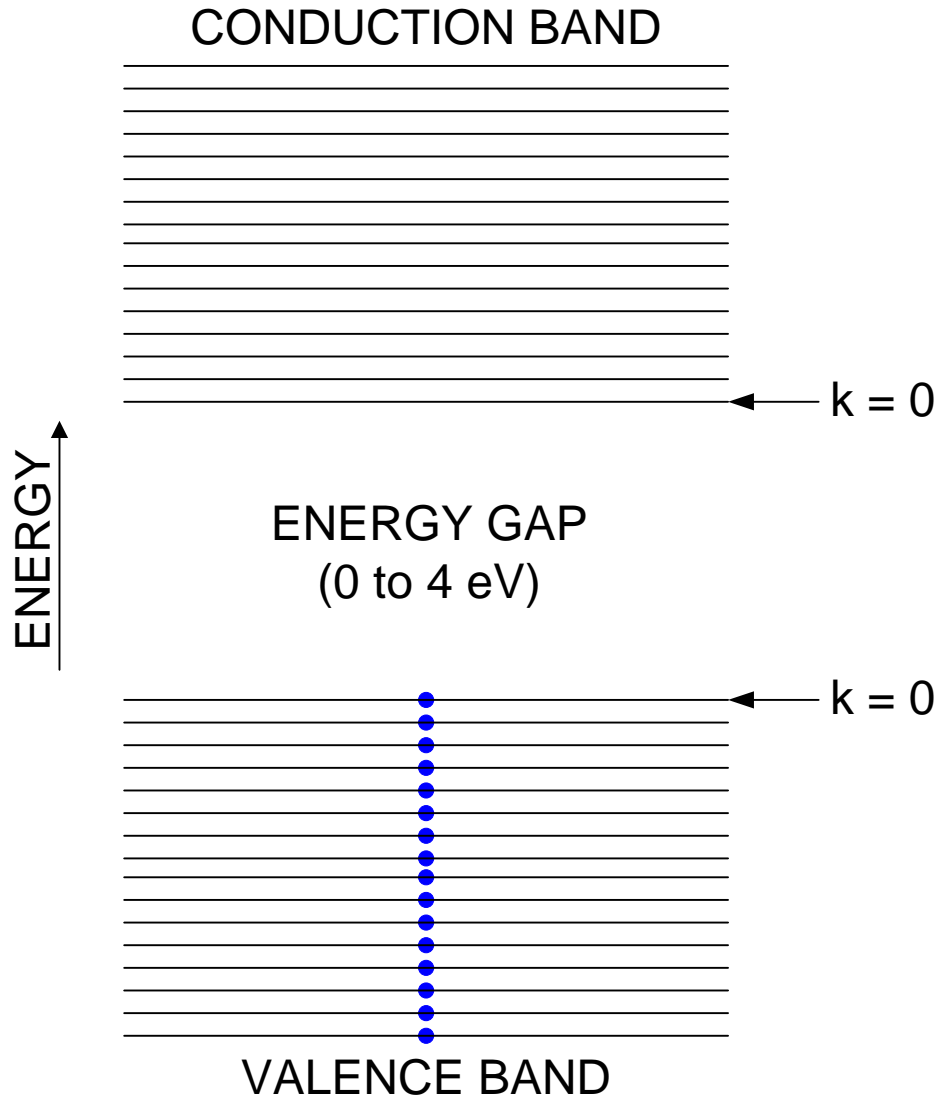

Figure 8. Energy bands in a semiconductor

Of particular interest is a pair of bands - a valence band, with energy levels completely (or very nearly completely) filled with electrons, and an empty (or very nearly empty) conduction band that lies just above the valence band (Figure 8). The “band gap” that lies between the valence and conduction band may have a width that ranges anywhere from 0 to 4 eV,

but band gaps of most technological interest are on the order of 1 eV. For energy bands relevant to the operation of a semiconductor laser, the states at the top and bottom of the valence and conduction band, respectively, have $k = 0$.

Figure 9 shows the energy bands of Figure 8 as curves of energy versus electron wavenumber. The curves in Figure 9 give a better feel for how the energy of electrons vary with the value k , and these type of curves are most often used for describing radiative processes in semiconductors. Figure 9 also shows a missing electron in the valence band that is referred to as a hole. In many ways, a hole acts much like an electron but with an opposite electric charge.

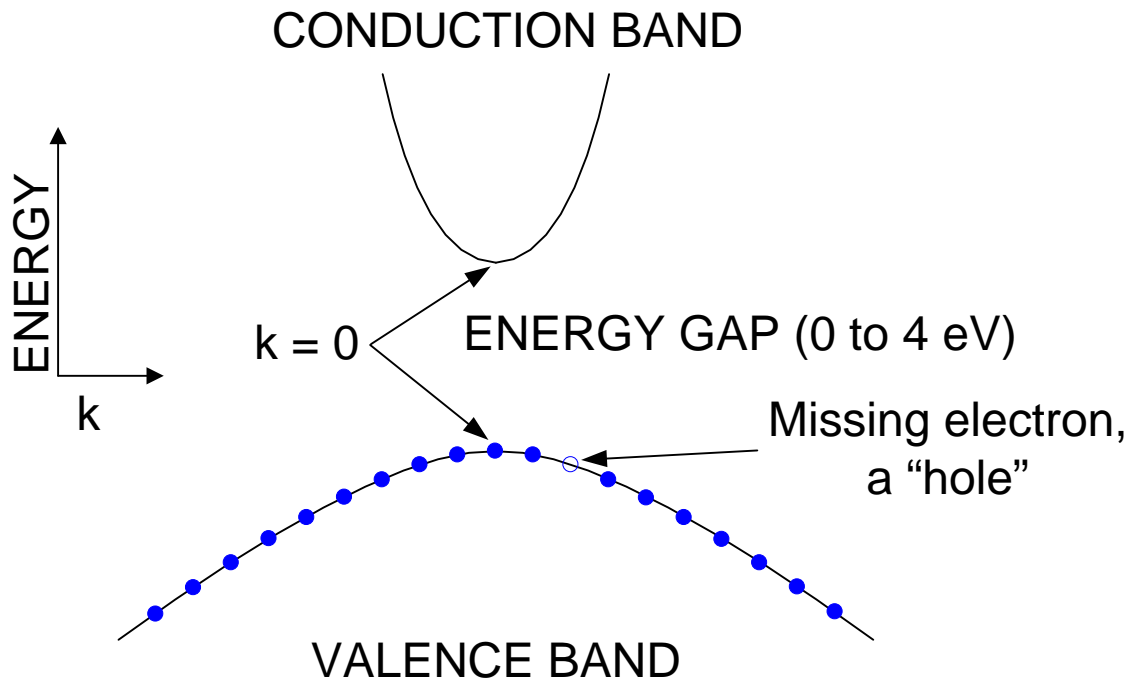

Figure 9. Valence and conduction bands in the energy versus momentum picture.

Another advantage of the E versus K curves is that they are better suited for displaying the multiple overlapping valence bands that are present in all semiconductors of interest. Figure 10 shows an E vs. k picture of a conduction band and two overlapping valence bands. The separate valence bands are easily distinguished by their curvature. Interactions with the crystal lattice causes electrons and holes in semiconductors to move as if they have a effective mass that differs from the free mass of the electron. The effective mass is determined by the curvature of the energy band – the greater the curvature, the smaller the effective mass. Thus we call the highly curved valence band in Figure 10 the light-hole band and the less curved valence band the heavy-hole band.

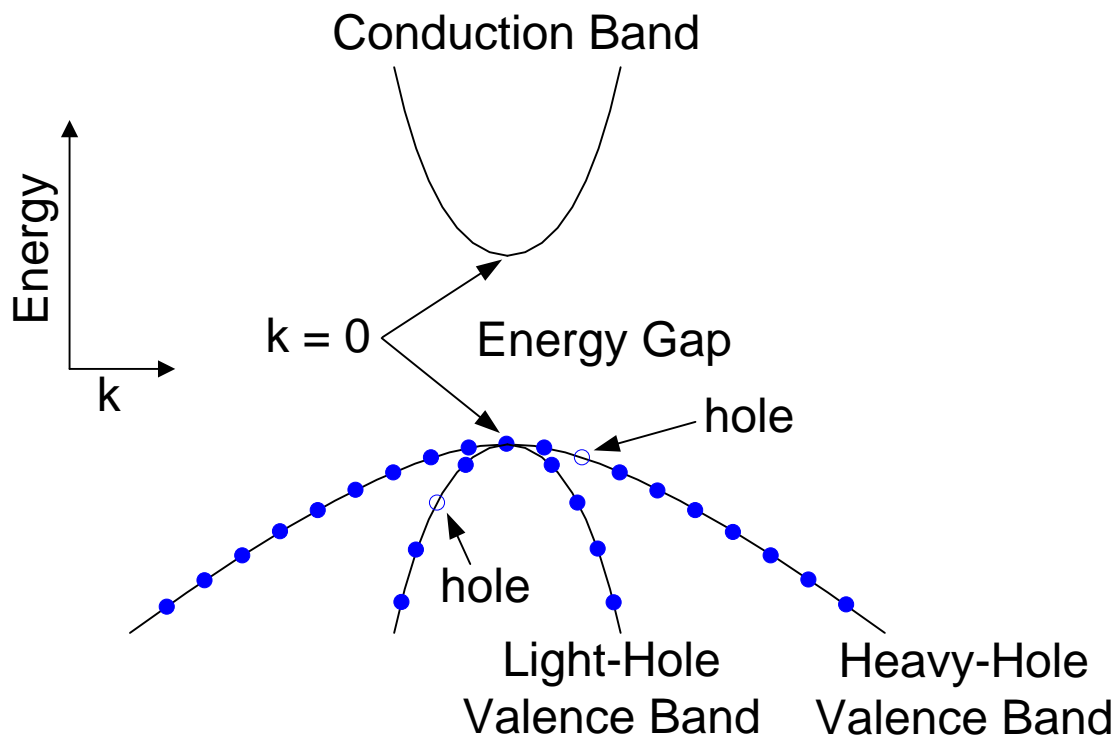

Figure 10. Energy versus momentum picture with two valence bands.

Optical Transitions in Semiconductors

As with atoms and molecules, radiative processes in semiconductors also include absorption, stimulated emission, and spontaneous emission. The strength of an optical interaction is also determined by the dipole moment between initial and final states, but it is common to describe selection rules that emphasize the importance of conservation of linear momentum. An optical transition between two energy levels in a semiconductor can take place only if

$$\hbar k_i = \hbar k_f \pm \hbar k_{\text{photon}},$$

where $\hbar k_i$ is the linear momentum of the electron in the initial state, $\hbar k_f$ is the electron momentum in the final state, and $\hbar k_{\text{photon}}$ is the momentum of the photon involved in the transition. The plus sign in the equation is used when the optical interaction is one of spontaneous or stimulated emission of a photon, while the minus sign is used for photon absorption.

Equivalently we can write momentum conservation in terms of wavenumbers:

$$k_i = k_f \pm k_{\text{photon}}.$$

Momentum and wavenumber conservation is illustrated in Figure 11 for the absorption of a photon and transition of an electron from a valence band to a conduction band.

Note that on the scale of the drawing, the wavenumber of the photon is very small so that the arrow in the drawing that connects the initial and final

electron states is almost vertical. Speaking approximately, we say that the transition is vertical, and we almost always make the approximation

$$k_i \approx k_f.$$

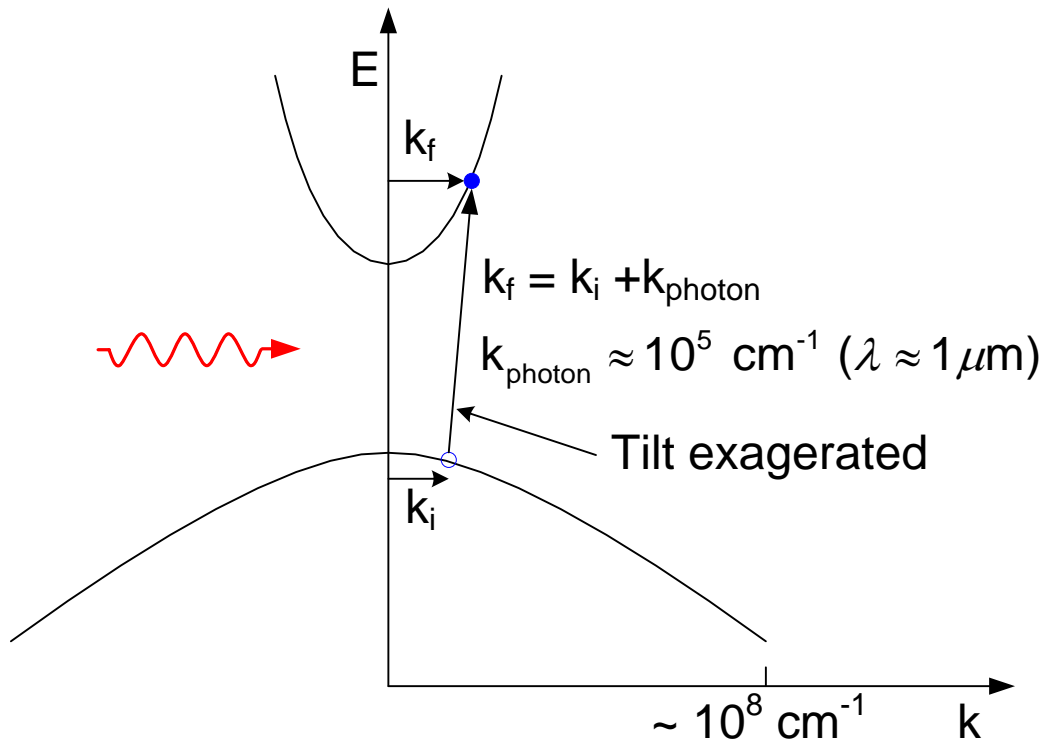

Figure 11. Optical transitions in semiconductors are “vertical”.

Population Inversion

Figure 12 is a simplified picture of a population inversion in a semiconductor with just two bands. All valence band states within a range of k values centered about $k = 0$ are empty, and an equal population of conduction band states about $k = 0$ are filled. Photons that are resonant with these states stimulate emission of additional photons, and light beams that contain these photons experience optical gain.

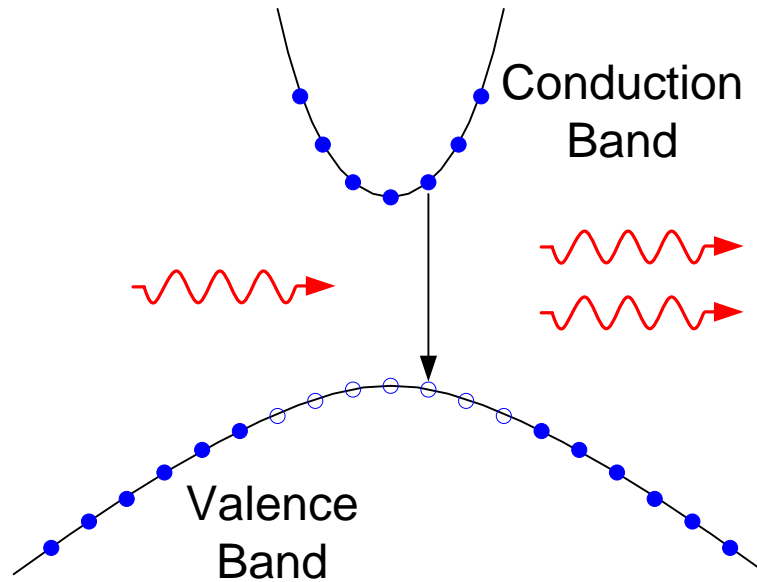

Figure 12. A simple picture of population inversion in a semiconductor.

A more precise picture of population inversion in semiconductors must include the concept of quasi-Fermi levels (Figure 13). When there are electrons in the conduction band, the probability that a state of energy E is occupied is given by the Fermi distribution

$$f_c(E_c) = \frac{1}{1 + e^{\frac{(E_c - F_c)}{kT}}},$$

where F_c is the quasi-Fermi level for the conduction band. Similarly, when there are holes in the valence bands, the probability that a state of energy E is occupied by a hole is

$$f_v(E_v) = \frac{1}{1 + e^{\frac{(F_v - E_v)}{kT}}},$$

where F_v is the quasi-Fermi level for the valence band.

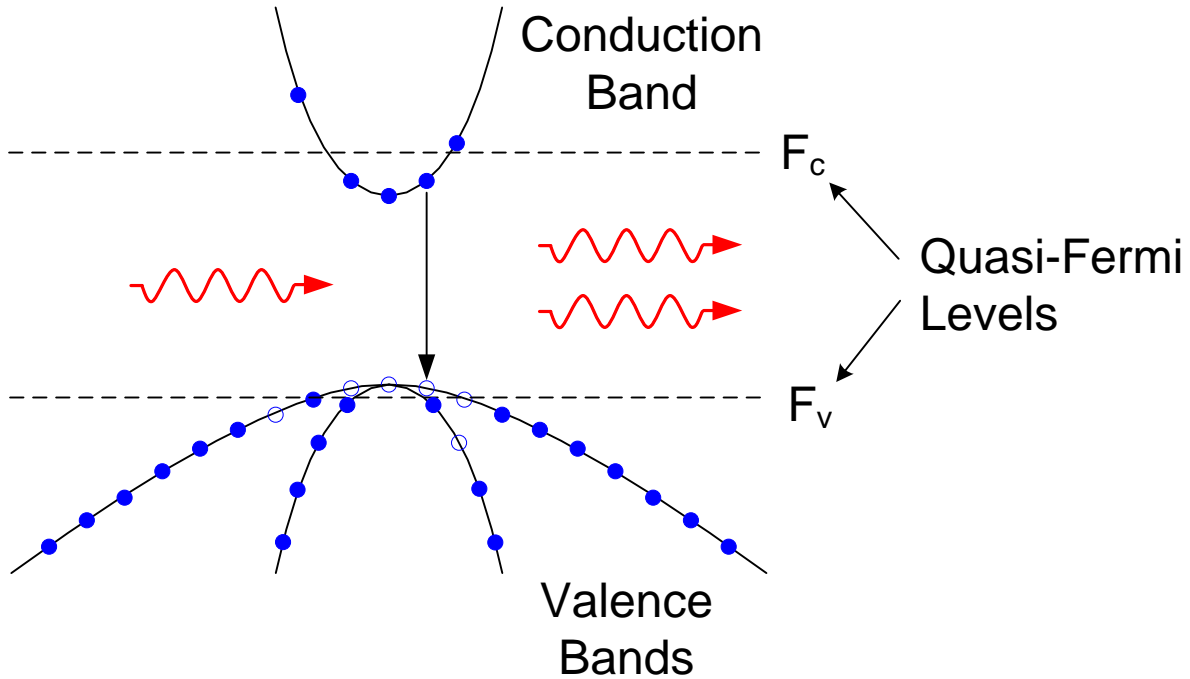

Figure 13. A more precise picture of population inversion in semiconductors includes quasi-Fermi levels.

The condition for optical gain for light resonant with energy levels E_c and E_v (i.e. $h\nu = E_c - E_v$) is

$$\underbrace{f_c(E_c)f_v(E_v)}_{\text{Proportional to the rate of stimulated emission}} - \underbrace{(1-f_c(E_c))(1-f_v(E_v))}_{\text{Proportional to the rate of photon absorption}} > 0.$$

It is not difficult to show that the condition for optical gain implies

$$F_c - F_v > E_c - E_v = h\nu.$$

Photons with a wide range of optical wavelengths can interact resonantly with a semiconductor, so whether or not we have optical gain depends on

the photon energy. We say we have a population inversion for those photons that experience gain.

The expression

$$F_c - F_v > h\nu$$

is known as the Bernard-Duraffourg relation.

Electrical Pumping

A p-n junction is used to create a population inversion in the “gain region” of a semiconductor (Figure 14). The p-n junction is forward biased by applying a voltage between metal electrodes on p and n-type semiconductor layers. The forward biased diode structure conducts current by injecting holes from the p-type semiconductor and electrons from the n-type semiconductor into the undoped gain region, placed between the p and n-type layers.

It is common to use a semiconductor with a relatively large band gap for the p and n-type layers and a semiconductor with a smaller band gap for the gain region. This combination forms a potential well that helps to confine electrons and holes to the gain region. The interface between two types of semiconductors is called a heterojunction. The arrangement of semiconductors in Figure 14 is called a double heterostructure, and a semiconductor laser (or light emitting diode) that uses the structure is called a double heterostructure laser (or light emitting diode).

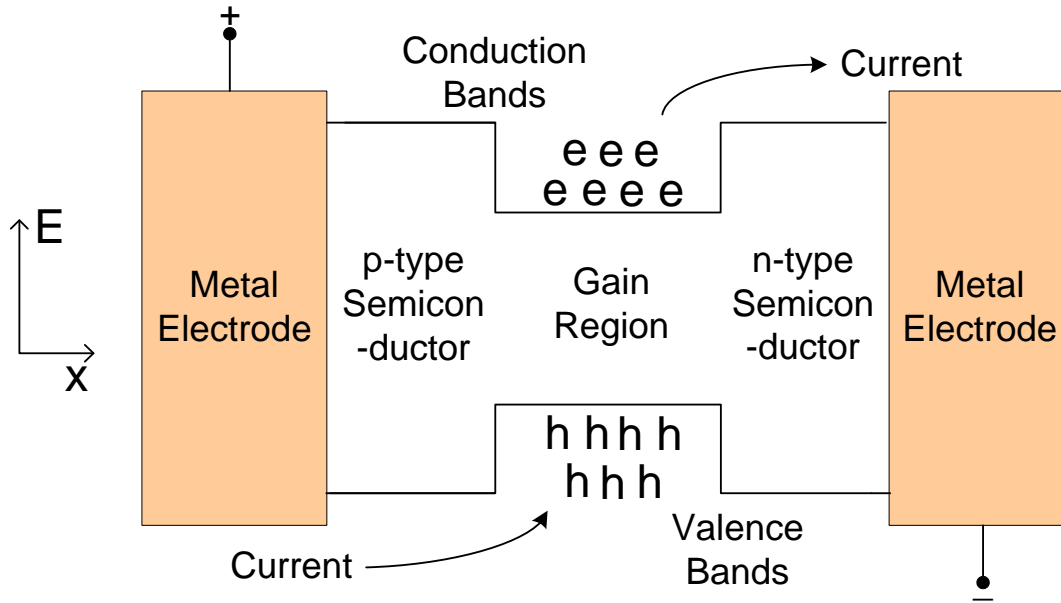

Figure 14. A double heterostructure, p-n junction for creating a population inversion in a semiconductor.

Non-Radiative Processes, Electron-Hole Lifetime, and Pumping Efficiency

In addition to the radiative processes considered above, there are non-radiative processes that also impact the operation of optical sources such as light emitting diodes and semiconductor lasers. In particular, non-radiative processes decrease optical source efficiency by converting pump energy into unusable and detrimental heat. In this section we will discuss the two most important non-radiative processes and introduce the concept of electron-hole lifetime.

Shockley-Read-Hall Recombination

Shockley-Read-Hall (SRH) recombination is called an “extrinsic” process because it requires the presence of impurity states in the energy gap that

would be absent in an ideal crystal. SRH recombination proceeds in the manner illustrated in Figure 15. A charged particle, say an electron, encounters a trap state in the middle of the forbidden gap of a semiconductor. There the electron waits for a hole to pass nearby. When the hole encounters the electron, they recombine. SRH recombination may produce infrared photons, but it is common to refer to this as a non-radiative process because any photons produced are outside of the region of interest.

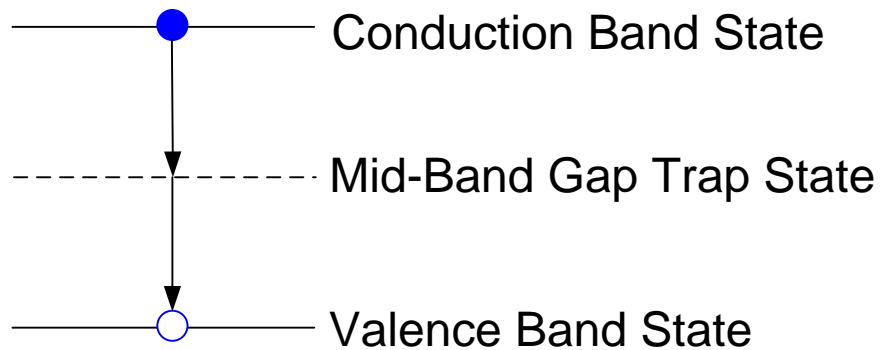

Figure 15. Shockley-Read-Hall type recombination of an electron with a hole.

It often turns out that the SRH recombination rate is proportional to density of electrons or the density of holes. A condition of charge neutrality forces equality of the density of electrons and holes (i.e. $n=p$) in the gain region of a semiconductor laser. Under these conditions it we can write

$$\frac{dn}{dt} = -A_{nr}n \quad \left(\text{or equivalently } \frac{dp}{dt} = -A_{nr}p \right).$$

This relation implies an exponential decay of n in time with a time constant

$$\tau_{SRH} = \frac{1}{A_{nr}}$$

that we will call the Shockley-Read-Hall lifetime. A typical value for SHR lifetime in a high-quality III-V semiconductor is on the order of a nanosecond.

Auger Recombination

Auger recombination is an “intrinsic” recombination mechanism that can occur in an ideal crystal without imperfections. There are several types of Auger recombination. The process illustrated in Figure 16 is called a CCCH Auger process because it involves three electron states in a conduction band and a hole in a valence band.

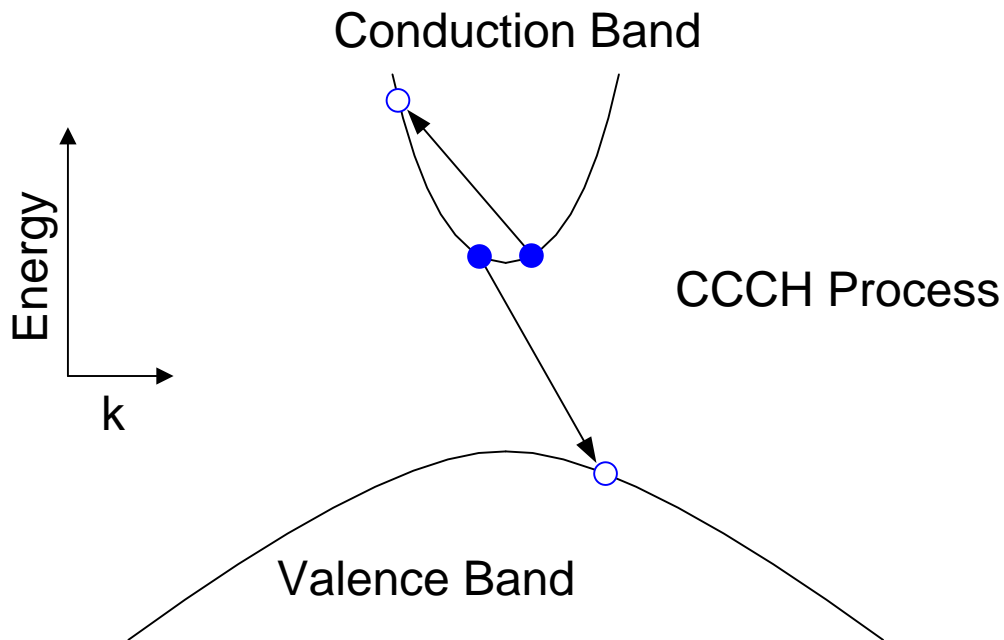

Figure 16. A CCCH Auger recombination process.

In the CCCH process an electron in the conduction band recombines with a hole. However, instead of producing a photon, the energy from the

recombination goes to promote a second electron in the conduction band to an energy that is higher in the band. The excited electron makes its way back to the bottom of the conduction band, emitting phonons (heat) on its way. The end result is pictured in Figure 17.

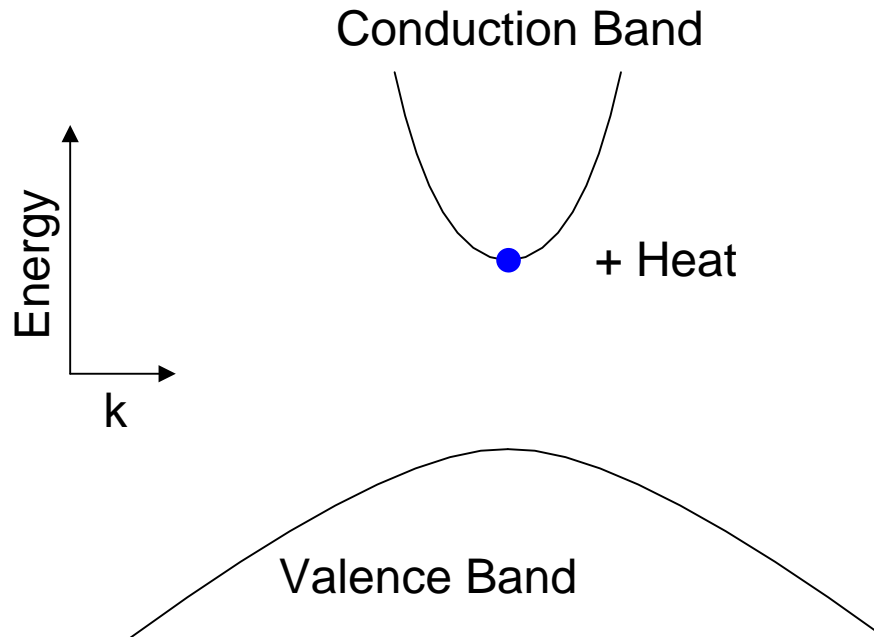

Figure 17. A CCCH Auger process removes an electron-hole pair from the semiconductor and converts the energy of the pair into heat.

Auger processes are “three body” processes, and the rate is given by

$$\frac{dn}{dt} = -Cn^3$$

when $n=p$. The decay of the population density n due to Auger processes is not exponential, but we can define a density dependent Auger lifetime

$$\tau_{Auger} = \frac{1}{n^2 C}$$

The last relation shows that the Auger rate increases rapidly and the lifetime drops rapidly with increasing population density. This is why Auger recombination is particularly important for the operation of light emitting diodes and semiconductor lasers with large electron-hole populations injected in the gain region. Auger recombination also tends to be larger for semiconductors with smaller band gaps such as those used for optical communication sources.